

Edson

Pedestal Mounted Engine Control *Installation Instructions* *Applies to Edson Part#'s 751, 816, 870*

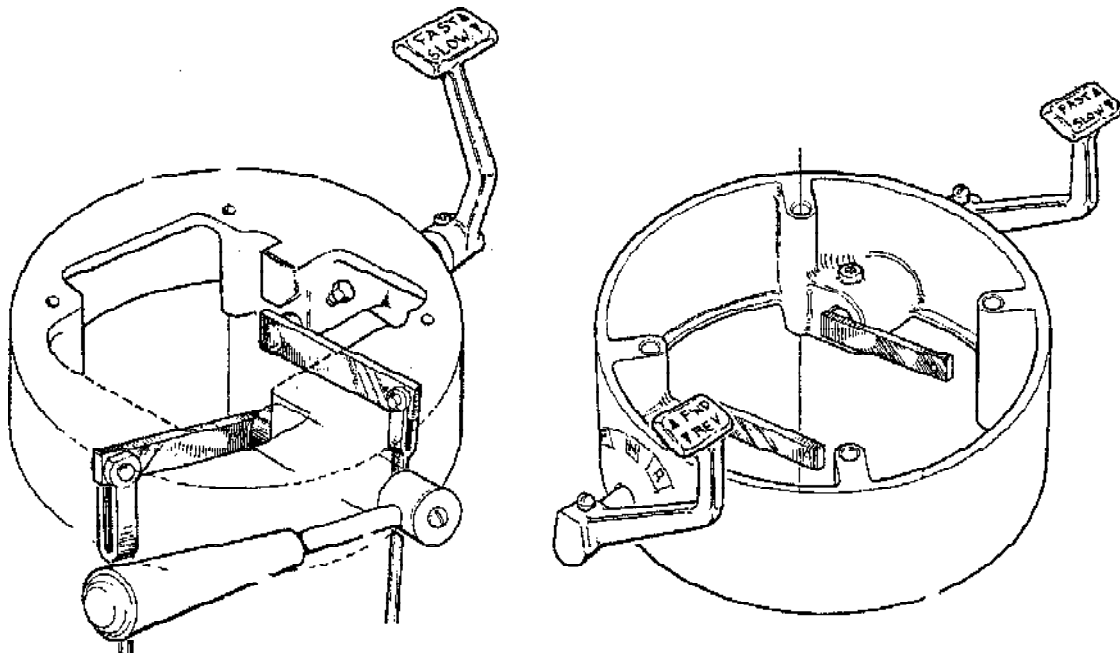

Description

Edson Pedestal Mount Engine Controls are designed for easy and convenient remote control of the engine. The controls mount easily to the top of any Edson Pedestal and the cables are led neatly inside the pedestal column. All models feature the clutch and throttle handles protected between the Steering Wheel and Pedestal Guard.

Edson Engine Controls use rugged stainless and marine grade aluminum components with minimum-maintenance oilless bearings and are pre-drilled to easily adapt to all Edson Pedestals.

Limitations

All Edson dual-lever Engine Controls are designed for use *only* with those transmissions having detents to locate and hold the transmission in gear. Only the Part #751 Engine Controls should be used with hard to shift "mechanical" transmissions such as the Atomic 4. Everyone on board the boat should be familiar with the maintenance and operation of the controls. All screws must be kept tight and cotter pins properly secured.

Parts Included

All Controls include:

- (1) Engine Control Assembly including:
 - (1) Engine Control Housing
 - (2) Engine Control Shafts/Levers
 - (2) Engine Control Handles
- (2) Shaft Bushings
- (2) Cable Clevises
- (4) Mounting Bolts
- (1) Cable Holder
- (1) Engine Control Decal
- (1) Warning Sticker

The actual part numbers vary from model to model for these items. See the table and drawings for part numbers for replacement parts.

| Edson Engine Control Replacement Parts (Part #'s 751,816,870) | | | | | | | |
|---|----------------|-------------|-----------------|-----------------|---------------|----------------|--------------|
| Engine Control | Throttle Cable | Shift Cable | Control Housing | Throttle Handle | Clutch Handle | Throttle Lever | Clutch Lever |
| Part # 816-45 | 734 | 734 | 960-C-135 | 963SB-55 | 960-A-1195 | 960-A-594-2 | 960-A-219 |
| Part # 816-6 | 734 | 734 | 960-C-132 | 963SB-55 | 960-A-1195 | 960-A-594-2 | 960-A-593 |
| Part # 870-45 | 734 | 734 | 960-C-279 | 963SB-55 | 963PT-55 | 960-A-938 | 960-A-938 |
| Part # 870-6 | 734 | 734 | 960-C-278 | 963SB-55 | 963PT-55 | 960-A-1055 | 960-A-1055 |
| Part #751-45 | 734 | 735 | 960-C-135 | 963SB-55 | 960-A-1158 | 960-A-594-2 | 960-A-593 |
| Part #751-6 | 734 | 735 | 960-C-132 | 963SB-55 | 960-A-1158 | 960-A-594-2 | 960-A-593 |

| Engine Control | Throttle Clevis | Clutch Clevis | Throttle Bushing | Clutch Bushing | Mounting Bolts | Cable Holder | Control Decal |
|----------------|-----------------|---------------|------------------|----------------|----------------|--------------|---------------|
| Part # 816-45 | 805-4.5 | 805-4.5 | 960-A-125 | 960-A-581 | 817-3.5 | 960-A-969 | 960-A-203 |
| Part # 816-6 | 805-4.5 | 805-4.5 | 960-A-125 | 960-A-581 | 817-3.5 | 960-A-969 | 960-A-203 |
| Part # 870-45 | 805-4.5 | 805-4.5 | 960-A-125 | 960-A-125 | 817-3.5 | 960-A-969 | 960-A-203 |
| Part # 870-6 | 805-4.5 | 805-4.5 | 960-A-125 | 960-A-125 | 817-3.5 | 960-A-969 | 960-A-203 |
| Part #751-45 | 805-4.5 | 810-225 | 960-A-125 | 960-A-581 | 817-3.5 | 960-A-705 | 960-A-203 |
| Part #751-6 | 805-4.5 | 810-225 | 960-A-125 | 960-A-581 | 817-3.5 | 960-A-705 | 960-A-203 |

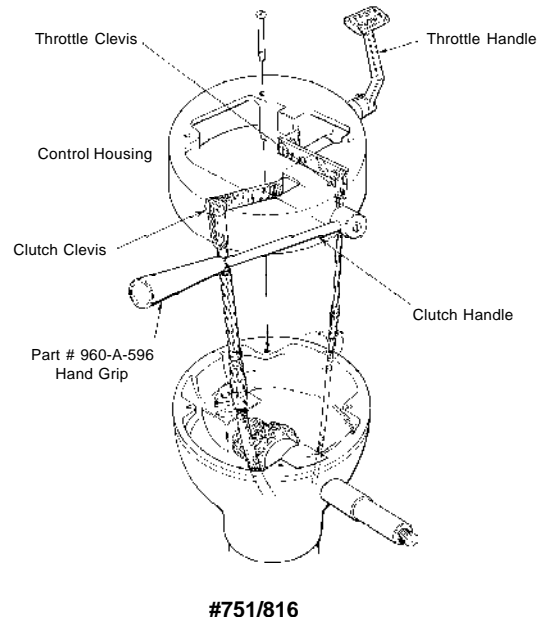
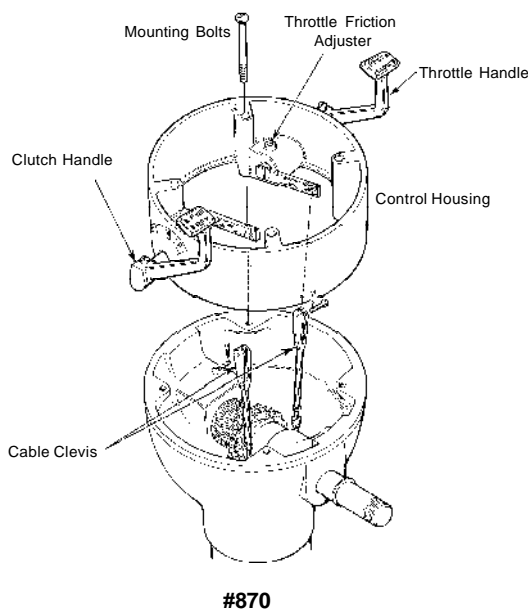

Planning the Installation

Edson Engine Controls are not provided with engine control cables. Available through Edson (Part# 734 and 735) or your local dealer, these cables come in various lengths to fit your installation. *You must measure the length required on your particular boat.* This should be measured approximately from the steering wheel shaft to the attachment point on the engine, taking into consideration any bends or necessary routing - cables should be led belowdecks with a generous radius. Tape or clamp to several structural members to reduce cable lost motion and prevent interference with sheaves and wire rope.

Edson Engine Controls use 33 Series Cables for the Throttle, and either a 33 Series or 64 Series Cable for the clutch. Which engine control to be used is ultimately determined by the size of the cable specified by your engine manufacturer. See the table below for information:

| Type Control | Size Edson Shift Cable Used | Size Edson Throttle Cable Used | Max. Clutch Cable Throw | Max. Throttle Cable Throw | Approx. Max. Operator Input for a Properly Adjusted Transmission |
|--------------|-----------------------------|--------------------------------|-------------------------|---------------------------|--|
| Part No. 751 | Part No. 735 | Part No. 734 | 3 3/4" (8.6 cm) | 3' (7.6 cm) | 15 to 20 lbs. (6.8 to 9 kg) |
| Part No. 870 | Part No. 734 | Part No. 734 | 3" (7.6 cm) | 3' (7.6 cm) | 5 to 10 lbs. (2.2 to 4.5 kg) |
| Part No. 816 | Part No. 734 | Part No. 734 | 3" (7.6 cm) | 3' (7.6 cm) | 10 to 15 lbs. (4.5 to 6.8 kg) |

NOTE: Max. cable throw figures on using Edson's standard 4" (10.2 cm) Column Pedestal.

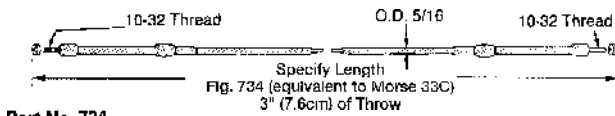

Part No. 734

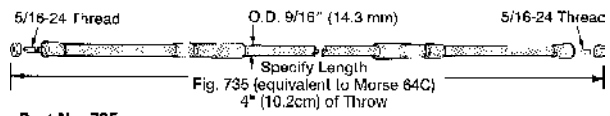

Part No. 735

Older Edson Pedestals (pre-1979) do not have a pre-drilled hole for mounting the Cable Holder. If there is no hole in the aft side of the pedestal tube, drill a 1/4" hole through the *AFT* side of the pedestal tube on centerline of pedestal 6 7/8" below the bottom of the wheel shaft.



Engine Connections

Use the information below as a guideline. Most engine and control cable manufacturers furnish instructions for installing their products. Use their instructions if there is any variance with the guidelines below.

- When aligning the cable anchor point with the control lever, the centerline of the cable must be aimed to the mid point of the lever to allow an equal amount of swivel to each other. No more than 10° of total cable bend is allowed.

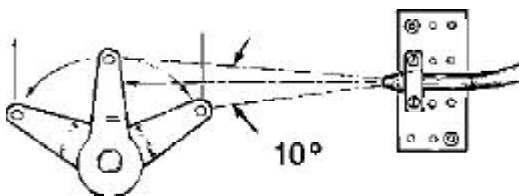

- Two holes are generally drilled in the engine throttle lever to optionally select the proper travel (1 3/4" or 2 3/4"). Inner hole will provide increased throttle travel and control handle pressure.

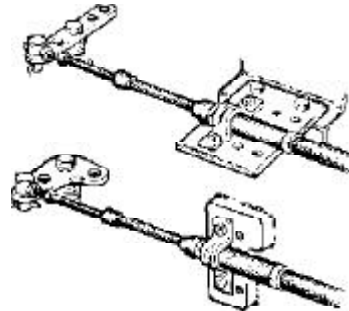

- Transmission cable direction may have to be reversed for correct directional control. Shown are different methods commonly used to do this.

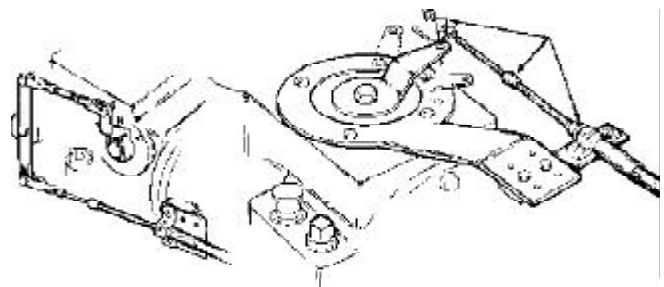

Engine Control Installation

Great care must be taken to assure ease and safety of engine controls operation. Components must be installed and adjusted so the engine goes into gear smoothly and completely and the throttle operates easily. Cables must be installed straight or in broad curves. See the Planning the Installation section for cable information.

1. If the cockpit floor is not already drilled for engine control cables, drill two 3/4" holes in the cockpit floor. The location of these holes should correspond with the holes in the aft side of the idler plate beneath the pedestal. Care should be taken that the engine control cables do not interfere with the steering cables.



2. Connect cables to engine according to engine manufacturer's instructions.

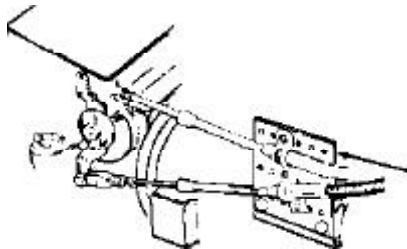

3. Remove compass from pedestal top. See compass manufacturer's instructions for compass removal.
4. Lead cables up through the bottom of the pedestal and out the top of the Pedestal *on the same side of the steering wheel shaft. The Shift cable should be on the left and the throttle cable on the right.*



5. Install cable holder on both cables as shown. Stainless Cotter Pin must securely hold both cables in place and the end must be bent to keep in place.



#816 & 870



#751

6. Screw both bronze forked clevis's to cable ends and secure with lock nut.



7. Push cables back down pedestal below the steering wheel shaft.

NOTE: With the cable holder attached to both cables, it will be a tight fit past the wheel shaft, chain and sprocket. Working space can be gained in the upper section of the pedestal by moving the chain forward of the sprocket. To do this, first tighten the brake, then ease the tension of the chain and steering cables by backing off the nuts on the takeup eyes located on the quadrant or radial wheel attached to the rudderpost. With slack steering cables and chain, lift the chain and move it forward of the sprocket hub.



8. Separate cable ends (Throttle on starboard and clutch on port.) Guide the cable holder into alignment with its screw hole in the aft side of the pedestal by holding onto the bronze clevises.



9. Attach cable holder to pedestal at hole location with the provided screw or nut. This screw should be secured with "Loctite" or similar thread lock.



10. Place engine control housing on top of pedestal - hold in place with two of the four 3 1/2" bolts.



11. Attach bronze clevises to throttle and clutch lever. Make sure that the throttle cable is attached to the throttle lever on the starboard side and the clutch cable is attached to the clutch lever. Secure with cotter pins.



12. Before mounting compass, test and adjust controls for proper directional control and movement.
13. Bolt down compass and engine control using the (4) 3 1/2" coated bolts. We suggest coating the bolts with anti-seizing compound to make later removal easier.



Instructions particular to #751 Engine Control

1. The shift lever should be horizontal when in neutral, up in reverse and down in forward.
2. Maximum clutch throw is 3 3/8" (86mm). On older pedestals, this may require filing off a corner of the compass mounting flange.
3. Attach the shift cable to the shift lever at a maximum distance of 5" (127mm) from the pivot.
4. Older marine engine transmissions require 35-40 foot pounds for the optimum clutch setting. This requires approximately 15-20 lbs input at the handle under average conditions.

Engine Control Adjustment

Engine control should give full engagement into forward and reverse as well as idle and full throttle. If the throw of the control does not allow full engagement, the bronze clevis attached to the control end of the cables can be adjusted in or out to allow for full cable travel and proper engagement. The control levers should not hit either the steering chain or compass compensating bars. Input required for operation should not exceed those shown in table on page 2.



Engine Control Operation

The Edson Engine Control should be used only after it has been properly installed and adjusted. Handles should operate smoothly and with minimal effort. When operating engine controls, never shift into or out of gear while throttle is above idle. ***Forcing the levers or shifting into or out of gear while above idle may result in broken cables, transmission wear or failure and loss of boat control.***

All on board should be familiar with the safe operation of the engine controls - caution and train all on board to their proper use.

Engine Control Maintenance

For best results your Edson Engine Controls should be routinely maintained. Make sure screws holding handles to the shafts are secure. Check clevis connections as well as clevis pins and cotter pins for wear. Replace or tighten any worn or loose parts. Make sure the screw or bolt attaching cable holder to pedestal is tight. Lubricate the control handle shafts and both cable ends with Teflon Spray. This will increase cable life and make operation easier. *Engine cables are subject to deterioration from high heat from the transmission as well as salty bilge water. Since they can not be internally lubricated, they have a typical lifespan of 5-7 years and should be replaced if corroded or stiff.*

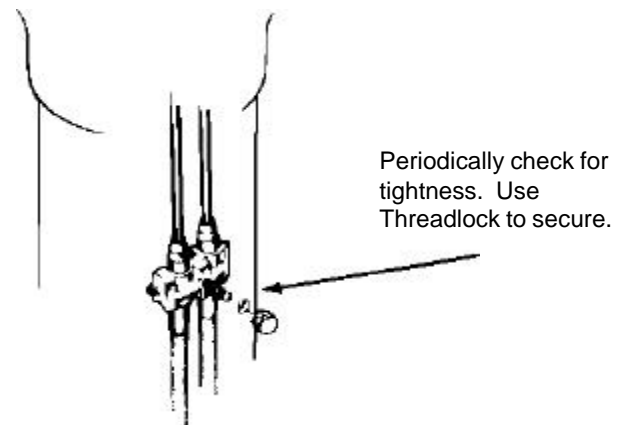
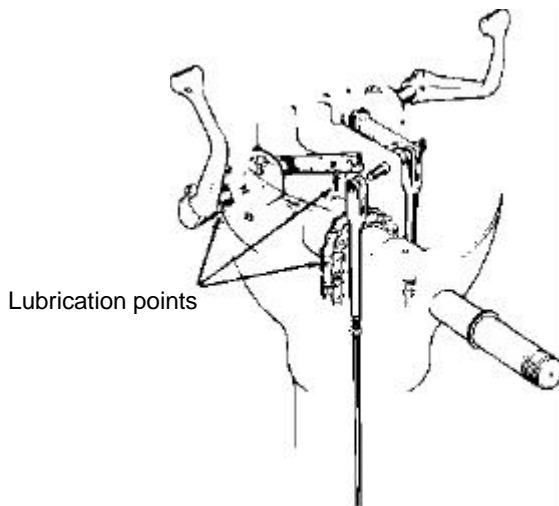

Troubleshooting

Most engine control problems are simply solved with minor adjustments. Listed below are common problems that you should be able to fix. If you still have a problem after following these steps, contact Edson Customer Service or your local dealer for more information.

Throttle or Clutch operation is backwards (pushing forward goes into reverse or idle):

There is no adjustment that can be made in the engine control to correct this; however, most engines have the ability to be reversed at the cable attachment point. The clutch cable is attached to an arm on the transmission that in most cases can be reversed for proper directional throw. Since most engines differ, please contact your engine manufacturer or dealer for information on reversing the throw of the throttle or clutch.

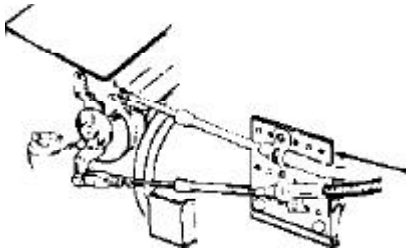

Throttle handle vibrates back to idle during use:

Tighten the throttle friction adjuster, located beneath the compass on the inside of the engine control housing on the top of the throttle shaft boss.



Handles are hard to move or are stiff:

If using new cables, make sure the route the cable takes from the pedestal takes no sharp or unnecessary bends. Make sure cable path is as straight and clear as possible. If you are using existing cables, check cable efficiency by disconnecting both ends of the cable and pushing and pulling disconnected cable. If the cable is still stiff, it should be replaced with a new one. Use only high-quality cables that can be purchased from Edson direct or from your local dealer. While the cables are disconnected from the engine, also try shifting the transmission by hand at the lever. If it is hard to shift, you should have it checked by a knowledgeable engine service technician.

Throttle or Clutch Handle hits pedestal guard before full engagement:

Make sure the cable holder is tightened and secured. The bronze clevis on the end of the clutch or throttle cable can be adjusted in or out to adjust the throw of the handle. By screwing the clevis further on the cable, the throw of the handle is adjusted further back, which should allow the handle to engage fully before hitting the guard pipe. If this is not enough adjustment, the engine end of the cable can often be adjusted to allow for the proper handle throw.

To make the adjustments at the engine disconnect the cable from the lever on the engine. Set the handle in the full forward (or full throttle) position with a spacer such as a 1" block of wood and tape the handle into place. At the engine adjust the clamp on the engine to a position so that the gear is fully engaged in forward (or full throttle) and reconnect the cable. Remove the tape and recheck that the full reverse (return to idle in the case of the throttle) is achieved.



Replacing Engine Control Cables

Replacing Cables

1) BUY YOUR REPLACEMENT CABLE

Determine type and length of engine control cable using measurements or markings from the original cable. Knowing the outside diameter of the original cable jacket will help determine the cable type and thread size. The length tip to tip of the cable core will give you the proper length.

2) REMOVE STEERING WHEEL

This will give you more room to work.

3) REMOVE COMPASS

Before removing the compass bolts, run a piece of electrical tape vertically from the compass across the engine control housing, top plate, and onto the pedestal. Slit the tape at each joint. This will help you realign the compass with the other parts when you reassemble this upper part of the pedestal. Remove the four round head 1/4-20 x 3-1/2 machine screws that serve as compass bolts.

4) REMOVE THE BRASS CLEVIS PINS FROM THE CONTROL LEVERS IN THE ENGINE CONTROL HOUSING

The clevises are screwed to the end of the engine control cables. Note which holes in the control levers the clevis pins came from. This helps when reassembling this unit.

5) REMOVE ENGINE CONTROL HOUSING

6) REMOVE THE CABLE HOLDER NUT OR ROUND HEAD MACHINE SCREW located on the aft side of the pedestal tube approximately 7" below the wheel shaft. This will release the Cable Holder (A-969 or A-705) that holds the two engine control cables. These cables remain attached to the cable holder inside the pedestal tube.

7) BRING BOTH CONTROL CABLES TO THE SAME SIDE OF WHEEL SHAFT.

From the top of the pedestal, push down both of the engine control cables just far enough so you can bring the throttle control cable (right hand side) under the wheel shaft and over to the left aft side of the pedestal along with the clutch cable.

8) PULL BOTH CONTROL CABLES UP.

With both control cables now on the same side of the steering wheel shaft, pull the cables up until you can reach the cable holder.

a) Twist the cables so that the bolt in the cable holder is pointing toward the sprocket. This should allow the cable holder to pass the sprocket.

a) Due to the limited amount of space in the pedestal tube the cable holder sometimes gets jammed up with the steering chain and cables. One solution to this problem is to turn the steering wheel shaft all the way to port, thus putting most of the steering chain over on the left side with the two engine control cables and cable holder. Then, while pulling up on the engine control cables, turn the steering wheel shaft back to starboard. The upward movement of the chain can help bring the cable holder and control cables up to a level where they can be reached.

b) Working space can be gained in the upper section of the pedestal by moving the chain forward of the chain sprocket. To do this, first tighten the brake, then ease the tension of

the chain and steering cables by backing off the nuts on the take-up eyes located on your radial drive wheel or quadrant which is attached to the rudderpost. With slack in the, steering cables, lift the steering chain and move it forward of the hub sprocket located on the steering wheel shaft.

9) REMOVE THE OLD CONTROL CABLE

Now that you can reach the cable holder, remove the old engine control cable. When removing the old engine control cable, make sure you attach a "messenger" line to the end of the original cable. You will use the messenger line to run the new replacement cable through the same route as the original engine control cable.

10) RUN THE NEW ENGINE CONTROL CABLE

Using the messenger line, pull the new engine control cable into place.

11) REASSEMBLE BY REVERSING THE ABOVE PROCEDURES.

a) Attach the new control cable to the cable holder.

b) Push both control cables down into the pedestal far enough so you can bring the throttle control cable under the steering wheel shaft and over to the right hand side.

c) Pull up and push aft on the engine control cables.

d) Line up the cable holder with its screw hole on the aft side of the pedestal. A long rod or screwdriver will help. The A-969 Cable Holder has a threaded (1/4-20) stud that sticks out through the hole. Use "Loctite" on thread. The A-705 Cable Holder is held in place with a round head (1/4-20 thread) screw that comes from the outside of the pedestal tube and screws into the cable holder. Use "Loctite" on threads.

e) Attach control cables to fittings on engine end.

f) Put engine control housing in place.

g) Attach clevises to engine control levers.

h) Before mounting compass use the four 3-1/2" (Fig 817 Sz. 3.5) compass mounting bolts to hold the engine control housing in place. Test and adjust the engine controls at this time.

i) Remove the four compass mounting bolts. Mount the compass using the original tape alignment marks, and screw compass mounting bolts back in place using an anti-seize compound on the threads.